

LS-138H II Machine Transport Weights – approximate

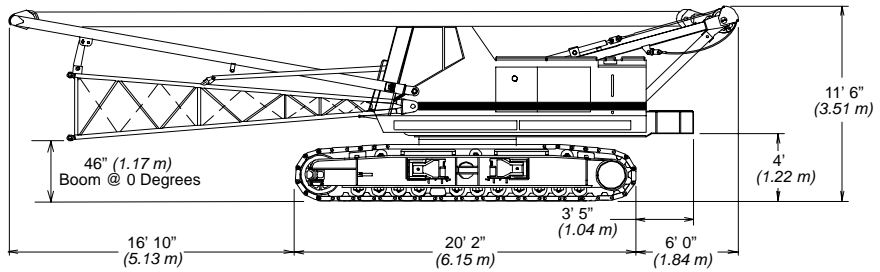

Transport Weight
Rope on both drums, Backstops, Catwalks, and 1/3 tank of fuel
Tube: 89,751 lbs. (40 710 kg)
Angle: 90,651 lbs. (41 119 kg)

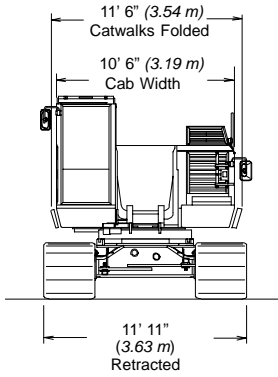
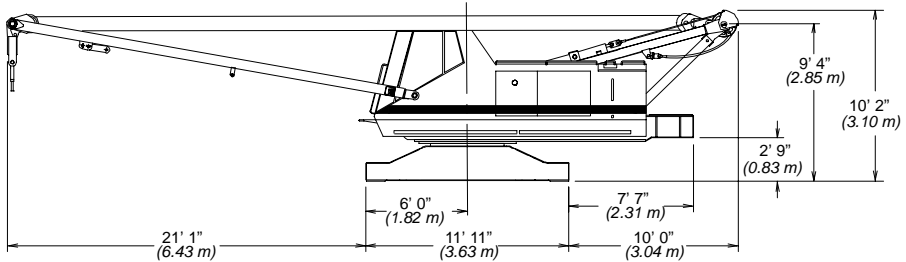
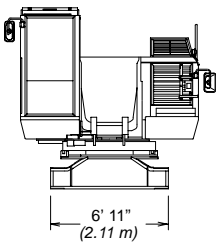

Upper & Carbody Shipping Weight
Rope on both drums, Backstops, Catwalks, and full of fuel
51,300 lbs. (23 269 kg)

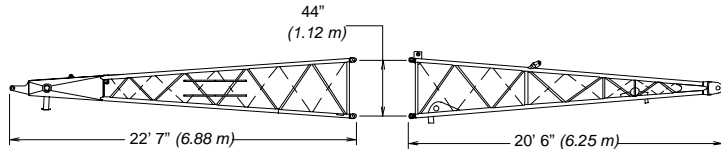
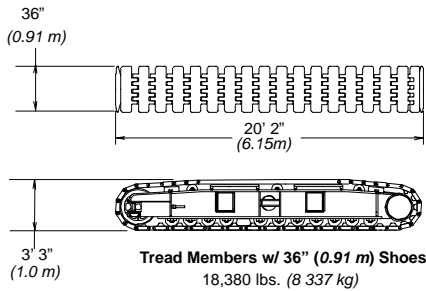

20' (6.10 m) Top Section
Tube: 2,726 lbs. (1 236 kg)
Angle: 3,500 lbs. (1 588 kg)

20' (6.10 m) Base Section
Tube: 1,720 lbs. (780 kg)
Angle: 2,853 lbs. (1 294 kg)

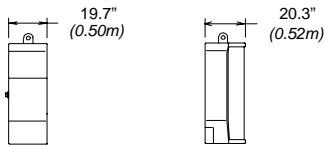

"A" Upper Counterweight 25,250 lbs. (11 453 kg)
"B" Upper Counterweight 25,250 lbs. (11 453 kg)

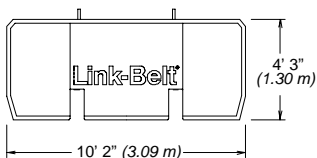
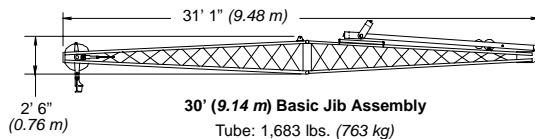

Front Mounted Third Drum w/o Rope
1,345 lbs. (610 kg)

LS-138H II Transportation Weights – approximate

Base Machine: Rigid Boom Backstops, 27 Gallons (102.2 L) of Fuel, Catwalks (front right and left side), 20' (6.10 m) Tube Base Section, 24' (6.10m) Live Mast, Bridle & Spreader Bar, 14-Part Boom Hoist Reeving, 700' (189 m) of Type 'DB' Front Hoist Rope, 540' (165m) of Type 'RB' Rear Hoist Rope.

| Item Description | Gross Weight | | Transport Loads | | | Notes and Load Summary |
|---|--------------|--------|-----------------|---------|---------|---|
| | lbs. | kg | Load #1 | Load #2 | Load #3 | |
| Base Machine | 89,751 | 40 710 | 1 | | | Numbers in the load columns to the left represent quantities. |
| Add "A" Counterweight | 25,250 | 11 453 | | | 1 | Estimated transport load assumes the load out consist of 200' (60.96 m) of tube boom + 60' (18.29 m) of jib with full counterweight. |
| Add "B" Counterweight | 25,250 | 11 453 | | 1 | | |
| Add Hydraulic Third Drum w/o rope | 1,345 | 610 | | | | Support loads were targeted at 45,000 lb (20 412 kg), 8'-6" (2.6 m) wide, 48' (14.63 m) long, and 13'-6" (4.11 m) high using a drop deck trailer. This may vary depending on state laws, empty truck/trailer weights, and style of trailer. |
| Add 20' (6.1m) Tube Top Section | 2,726 | 1 237 | | 1 | | |
| Add 10' (3.05m) Tubular Extension w/pins & pendants | 677 | 307 | | | 1 | Support loads were targeted at 45,000 lb (20 412 kg), 8'-6" (2.6 m) wide, 48' (14.63 m) long, and 13'-6" (4.11 m) high using a drop deck trailer. This may vary depending on state laws, empty truck/trailer weights, and style of trailer. |
| Add 20' (6.1m) Tubular Extension w/pins & pendants | 1,076 | 488 | | 1 | 2 | |
| Add 30' (9.1m) Tubular Extension w/pins & pendants | 1,481 | 672 | | 2 | 1 | Support loads were targeted at 45,000 lb (20 412 kg), 8'-6" (2.6 m) wide, 48' (14.63 m) long, and 13'-6" (4.11 m) high using a drop deck trailer. This may vary depending on state laws, empty truck/trailer weights, and style of trailer. |
| Add 20' (6.1m) Angle Base Section at 0 degrees | 2,853 | 1 294 | | | | |
| Add 20' (6.1m) Angle Top Section with 4 Lifting Sheaves | 3,500 | 1 588 | | | | Support loads were targeted at 45,000 lb (20 412 kg), 8'-6" (2.6 m) wide, 48' (14.63 m) long, and 13'-6" (4.11 m) high using a drop deck trailer. This may vary depending on state laws, empty truck/trailer weights, and style of trailer. |
| Add 20' (6.1m) Angle Top Section with 3 Lifting Sheaves | 3,400 | 1 592 | | | | |
| Add 20' (6.1m) Angle Top Section with 2 Lifting Sheaves | 3,300 | 1 497 | | | | Support loads were targeted at 45,000 lb (20 412 kg), 8'-6" (2.6 m) wide, 48' (14.63 m) long, and 13'-6" (4.11 m) high using a drop deck trailer. This may vary depending on state laws, empty truck/trailer weights, and style of trailer. |
| Add 10' (3.05m) Angular Extension w/pins & pendants | 1,040 | 472 | | | | |
| Add 20' (6.1m) Angular Extension w/pins & pendants | 1,680 | 762 | | | | Support loads were targeted at 45,000 lb (20 412 kg), 8'-6" (2.6 m) wide, 48' (14.63 m) long, and 13'-6" (4.11 m) high using a drop deck trailer. This may vary depending on state laws, empty truck/trailer weights, and style of trailer. |
| Add 30' (9.1m) Angular Extension w/pins & pendants | 2,400 | 1 089 | | | | |
| Add Bridle & Spreader Bar Only (No Live Mast) | 990 | 449 | | | | Support loads were targeted at 45,000 lb (20 412 kg), 8'-6" (2.6 m) wide, 48' (14.63 m) long, and 13'-6" (4.11 m) high using a drop deck trailer. This may vary depending on state laws, empty truck/trailer weights, and style of trailer. |
| Add Tagline Winder | 760 | 345 | | | | |
| Add Fairleader | 500 | 227 | | | | Support loads were targeted at 45,000 lb (20 412 kg), 8'-6" (2.6 m) wide, 48' (14.63 m) long, and 13'-6" (4.11 m) high using a drop deck trailer. This may vary depending on state laws, empty truck/trailer weights, and style of trailer. |
| Add PAT DS-350 | 100 | 45 | | | | |
| Add 30' (9.1m) Tubular Jib | 1,683 | 763 | | | 1 | Support loads were targeted at 45,000 lb (20 412 kg), 8'-6" (2.6 m) wide, 48' (14.63 m) long, and 13'-6" (4.11 m) high using a drop deck trailer. This may vary depending on state laws, empty truck/trailer weights, and style of trailer. |
| Add 15' (4.6m) Tubular Jib Extension | 317 | 144 | | | 2 | |
| Add 5' (1.5m) Auxiliary Tip Extension | 800 | 363 | | | | Support loads were targeted at 45,000 lb (20 412 kg), 8'-6" (2.6 m) wide, 48' (14.63 m) long, and 13'-6" (4.11 m) high using a drop deck trailer. This may vary depending on state laws, empty truck/trailer weights, and style of trailer. |
| Add Holding Rope – 0.88" X 165' Type 'DB' | 234 | 106 | | | | |
| Add Closing Rope – 0.88" X 220' Type 'DB' | 312 | 142 | | | | Support loads were targeted at 45,000 lb (20 412 kg), 8'-6" (2.6 m) wide, 48' (14.63 m) long, and 13'-6" (4.11 m) high using a drop deck trailer. This may vary depending on state laws, empty truck/trailer weights, and style of trailer. |
| Add Inhaul Rope – 0.88" X 80' Type 'M' | 108 | 49 | | | | |
| Add Hoist Rope – 0.88" x 165' Type 'DB' | 234 | 106 | | | | Support loads were targeted at 45,000 lb (20 412 kg), 8'-6" (2.6 m) wide, 48' (14.63 m) long, and 13'-6" (4.11 m) high using a drop deck trailer. This may vary depending on state laws, empty truck/trailer weights, and style of trailer. |
| Add Jib Wire Rope – 0.88" X 700' Type 'DB' | 994 | 451 | | | | |
| Add 3rd Drum Wire Rope 0.63" X 385' Type 'ZB' | 312 | 142 | | | | Support loads were targeted at 45,000 lb (20 412 kg), 8'-6" (2.6 m) wide, 48' (14.63 m) long, and 13'-6" (4.11 m) high using a drop deck trailer. This may vary depending on state laws, empty truck/trailer weights, and style of trailer. |
| Add 3rd Drum Wire Rope 0.63" X 385' Type 'WB' | 296 | 134 | | | | |
| Add Auxiliary Lifting Bail | 200 | 91 | | | | Support loads were targeted at 45,000 lb (20 412 kg), 8'-6" (2.6 m) wide, 48' (14.63 m) long, and 13'-6" (4.11 m) high using a drop deck trailer. This may vary depending on state laws, empty truck/trailer weights, and style of trailer. |
| Add 15-ton (13.6mt) Hook Ball – Non Swivel | 750 | 340 | | 1 | | |
| Add 15-ton (13.6mt) Hook Ball – Swivel | 760 | 345 | | | | Support loads were targeted at 45,000 lb (20 412 kg), 8'-6" (2.6 m) wide, 48' (14.63 m) long, and 13'-6" (4.11 m) high using a drop deck trailer. This may vary depending on state laws, empty truck/trailer weights, and style of trailer. |
| Add 80-ton (72.6mt) 4 Sheave Hook Block | 2,325 | 1 055 | | 1 | | |
| Remove 20' Tube Base Section | -1,988 | -902 | | | | Support loads were targeted at 45,000 lb (20 412 kg), 8'-6" (2.6 m) wide, 48' (14.63 m) long, and 13'-6" (4.11 m) high using a drop deck trailer. This may vary depending on state laws, empty truck/trailer weights, and style of trailer. |
| Remove Front Hoist Rope 0.88" X 700' Type 'DB' | -944 | -451 | | | | |
| Remove Jib Wire Rope 0.88" X 540' Type 'RB' | -810 | -367 | | | | Support loads were targeted at 45,000 lb (20 412 kg), 8'-6" (2.6 m) wide, 48' (14.63 m) long, and 13'-6" (4.11 m) high using a drop deck trailer. This may vary depending on state laws, empty truck/trailer weights, and style of trailer. |
| Remove 24' (7.3m) Live Mast with Bridle & Spreader Bar | -2,618 | -1 188 | | | | |
| Add 50 gallons (189.3L) of Fuel | 362 | 164 | | | | Support loads were targeted at 45,000 lb (20 412 kg), 8'-6" (2.6 m) wide, 48' (14.63 m) long, and 13'-6" (4.11 m) high using a drop deck trailer. This may vary depending on state laws, empty truck/trailer weights, and style of trailer. |

Machine Working Weight

| Option | Description | Gross Weight lbs. (kg) | Ground Bearing Pressure psi (kg/cm ²) |
|--------|---|------------------------|---|
| 1 | Base Machine equipped with 40' (12.2 m) of tubular boom, live mast, "A" counterweight, 700' (213 m) front hoist rope, 540' (164.6 m) rear hoist rope, 80-ton (72.6 mt) hook block, 77 gallons (291.4 L) of fuel, and a 200 lbs. (90.7kg) operator. | 121,097 (54 929) | 7.71 (0.54) |
| 2 | Option #1 plus "B" counterweight, midpoint pendants, and 160' (48.77m) of boom extensions to obtain 200' (60.96 m) of main boom. | 155,627 (70 591) | 9.92 (0.70) |
| 3 | Option #2 plus 60' (18.29 m) of jib and 15-ton (13.61 mt) hookball – subtract 20' (6.10 m) of boom extension and midpoint pendants to obtain maximum 180' + 60' (54.86 + 18.29 m) of main boom + jib. | 157,452 (71 419) | 10.03 (0.70) |
| 4 | Base Machine equipped with 40' (12.20 m) of angle boom, live mast, "A" counterweight, 700' (213 m) front hoist rope, 540' (164.59 m) rear hoist rope, 80-ton (72.57 mt) hook block, 77 gallons (291.4 L) of fuel, and a 200 lbs. (90.7kg) operator. | 121,722 (55 212) | 7.76 (0.54) |
| 5 | Option #4 plus "B" counterweight and 110' (33.55 m) of boom extensions to obtain 150' (45.72 m) of main boom. | 156,172 (70 838) | 9.95 (0.71) |
| 6 | Option #5 plus 60' (18.29 m) of jib and 15-ton (13.61 mt) hookball to obtain maximum 150' + 60' (45.72 + 18.29 m) of main boom + jib. | 155,387 (70 482) | 9.90 (0.70) |

Notes:

- Ground bearing pressure is based on the total weight distributed evenly over the track contact area.
- Total contact area for 36" (0.91m) track shoes is 15,689 in² (101,219cm²).

Attachment Options

■ 40'–200' Tube Boom (12.19 – 60.96 m)

Basic Tube Boom – 40' (12.19 m) two-piece design that utilizes a 20' (6.10 m) base section and a 20' (6.10 m) open throat top section with in-line connecting pins on 54" (1.37 m) wide and 44" (1.12 m) deep centers.

- Boom feet on 50" (1.27 m) centers
- 3" (76.2 mm) diameter chords
- Lugs on base section to attach carrying links
- Skywalk platform
- Deflector roller on top section
- Permanent skid pads mounted on top section to protect head machinery
- Rigid sheave guards
- Five 18" (0.46 m) root diameter steel sheaves mounted on sealed anti-friction bearings
- Mechanical boom angle indicator

Optional – Handling system that mounts in the boom base to allow loading/unloading of a counterweight or a boom section onto transport trailers.

Tube Boom Extensions – The following table provides the lengths available and the suggested quantity to obtain maximum boom in 10' (3.05 m) increments. Midpoint pendant connections are required at 80' (24.38 m) for 190' (57.91 m) and 200' (60.96 m) boom lengths.

| Tube Boom Extensions | Suggested Quantity for Max. Boom |
|----------------------|----------------------------------|
| 10' (3.05 m) | 1 |
| 20' (6.10 m) | 1 |
| 30' (9.14 m) | 4 |

- Deflector roller on top of each section
- Appropriate length pendants
- Maximum tube boom tip height of 204' (62.18 m)

■ 40'–150' Angle Boom (12.19 – 45.72 m)

Basic Angle Boom – 40' (12.19 m) two-piece design that utilizes a 20' (6.10 m) base section and a 20' (6.10 m) open throat top section with in-line connecting pins. Boom extensions are 48" (1.22 m) wide and 48" (1.22 m) deep at outside dimensions of angles.

- Boom feet on 50" (1.27 m) centers
- 4" X 4" X 0.38" (101.6 x 101.6 x 9.5 mm) angle chords
- Lugs on base section to attach carrying links
- Skywalk platform
- Deflector roller on top section
- Permanent skid pads mounted on top section to protect head machinery
- Rigid sheave guards
- Four 18" (0.46 m) root diameter steel sheaves mounted on sealed anti-friction bearings
- Mechanical boom angle indicator

Optional – Three sheave head machinery for clam applications or two wide sheaves for dragline applications

Angle Boom Extensions – The following table provides the lengths available and the suggested quantity to obtain maximum boom in 10' (3.05 m) increments. Midpoint pendant connections are not required.

| Angle Boom Extensions | Suggested Quantity for Max. Boom |
|-----------------------|----------------------------------|
| 10' (3.05 m) | 1 |
| 20' (6.10 m) | 2 |
| 30' (9.14 m) | 2 |

- Deflector roller on top of each section
- Appropriate length pendants
- Maximum angle boom tip height of 154' (46.94 m)

■ 30' – 60' Tube Jib (9.14– 18.29 m)

Basic Tube Jib – 30' (9.14 m) two-piece design that utilizes a 15' (4.57 m) base section and a 15' (4.57 m) top section with in-line connecting pins on 32" (0.81 m) wide and 24" (0.61 m) deep centers.

- 2" (50.8 mm) diameter tubular chords
- One 18.5" (0.47 m) root diameter steel sheave mounted on sealed anti-friction bearings.
- 15' (0.38 mm) jib extensions provide jib lengths at 45' (13.76 m) and 60' (18.29 m)
- Jib offset angles at 5, 15 and 25 degrees
- Maximum tip height of boom + jib is 242' (73.76 m) using the tube boom and 204' (62.53 m) using the angle boom

■ Auxiliary 5' (1.52 m) Tip Extension

Designed to use instead of a jib to provide clearance between working hoist lines. The extension is equipped with a single 15.25" (0.39 m) root diameter steel sheave mounted on sealed anti-friction bearings. Maximum capacity is 9-ton (8.16 mt).

■ Boom Hoist System

Designed to lift off maximum boom or maximum boom plus jib unassisted. Operates up to a maximum boom angle of 82 degrees. Automatically limits maximum boom angle operation.

- Retractable gantry frame
- Pin-on bail frame
- 14-part reeving with 5/8" (14.7 mm) type 'W' wire rope
- Bridle assembly
- 24' (7.31 m) live mast (optional for angle attachment)
- Two 1.25" (31.75 mm) pendants
- Telescopic boom backstops (tubular-type)
- Sheaves contain sealed anti-friction bearings
- Boom speed from 10°–70° is 52 seconds with no load and 94 seconds with full load. Speed was determined using 100' (30.5 m) of tube boom

Revolving Upperstructure

■ Frame

All welded steel frame with precision machined surfaces for mating parts.

■ Engine

| | |
|--|-------------------------|
| Isuzu A-6SDITQB with oil cooler, oil cooler, air cleaner, fuel filter, water separator, hour meter, tachometer, and electrical shutdown. | |
| Number of cylinders | 6 |
| Bore and stroke – in (mm) | 4.72 x 5.71 (120 x 145) |
| Piston displacement – in ³ (cm ³) | 600 (9 839) |
| Engine rpm at full load speed | 2,100 |
| Hi-idle rpm | 2,325 |
| Full load speed – horsepower (kw) | 207 (155) |
| Peak torque – ft lb (joule) | 513 (696) |
| Peak torque – rpm | 1,400 |
| Electrical system | 24 volt |
| Batteries | 2-12 volt |
| Approximate fuel consumption | Gal./hr (L/hr) |
| 100% H.P. | 11.50 (43.53) |
| 75% H.P. | 8.60 (32.55) |
| 50% H.P. | 5.75 (21.77) |
| 25% H.P. | 2.87 (10.86) |

■ Hydraulic System

Hydraulic Pumps – The pump arrangement is designed to provide hydraulically powered functions allowing positive, precise control with independent or simultaneous operation of all crane functions.

- Two variable displacement pumps operating at 4,000 psi (281.24 kg/cm²) and 64 gal/min (243 l/min) powers load hoist drums, boom hoist drum, optional third drum, and travel.
- One fixed displacement gear type pump operating at 3,600 psi (250 kg/cm²) and 32 gal/min (121 l/min) powers the swing, and treadmember retract cylinders.
- One fixed displacement gear type pump operating at 1,250 psi (85 kg/cm²) and 8 gal/min (32 l/min) powers the pilot control system, clutches, brakes, pump controls, counterweight removal system, and optional handling system mounted in boom base.

Pump Control (“Fine Inching”) mode

Special pump setting, selectable from operator’s cab, that allows very slow movements of load hoist drums, boom hoist drum, and travel for precision work.

Hydraulic Reservoir – 78 US gallons (295 l), equipped with sight level gauge. Diffusers built in for deaeration.

Filtration – One 10 micron, full flow, line filter in the control circuit. All oil is filtered prior to entering the reservoir.

Counterbalance Valves – All hoist motors are equipped with counterbalance valves to provide positive load lowering and prevent accidental load drop if the hydraulic pressure is suddenly lost.

■ Load Hoist Drums

Each drum contains a pilot controlled, bi-directional, axial piston motor and a planetary gear reduction unit to provide positive control under all load conditions.

- Power up/down & free-fall operation modes
- Automatic brake mode (spring applied, hydraulically released, band type brake)
- 0.88” (22.22 mm) grooved lagging
- Drum pawl controlled manually
- Electronic drum rotation indicators
- Mounted on anti-friction bearings
- 17.64” (0.45 m) root diameter
- 29.92” (0.76 m) flange diameter
- 19.84” (0.50 m) width

Note: The freefall operational mode is designed to prevent load lowering even if the freefall switch is accidentally activated. The automatic brake mode meets all OSHA requirements for personnel handling.

Drum Clutches – Speed-o-Matic™ power hydraulic two shoe clutch design that uses a 20” (0.51 m) diameter x 5” (127 mm) wide shoe that internally expands to provide load control. Swept area is 314 in² (2 026 cm²).

■ Optional Front Mounted Third Hoist Drum

The hydraulic winch is pinned to the front of the upper frame and is used in conjunction with a fleeting sheave and 3-sheave idler assembly to run the wire rope over the boom top section.

- Free-spooling capability for pile driving applications
- 10.63” (0.27 m) root diameter
- 20” (0.51 m) outside flange diameter
- 13.5” (0.34 m) width
- Mounted on anti-friction bearings

■ Boom Hoist Drum

Contains a pilot controlled, bi-directional, axial piston motor and a planetary gear reduction unit to provide positive control under all load conditions.

- Spring applied, hydraulically released, disc type brake controlled automatically
- 5/8” (15.88 mm) grooved lagging
- Drum pawl controlled manually
- Mounted on anti-friction bearings
- 12.60” (0.31 m) root diameter
- 24.41” (0.62 m) flange diameter
- 9.57” (0.24 m) width

■ Swing System

Mechanical linkage controls the bi-directional axial piston motor and the planetary gear reduction unit to provide positive control under all load conditions.

- Spring applied, hydraulically released, 360 degree multi-plate brake
- Free swing mode when lever is in neutral position
- Two position positive house lock
- Audio/Visual swing alarm
- Maximum swing speed is 2.8 rpm

■ Upper Counterweight

Consist of a two piece design that can be easily lowered to the ground using the gantry.

- 25,250 lbs. (11 453 kg) “A” upper counterweight
- 25,250 lbs. (11 453 kg) “B” upper counterweight can be added to maximize capacities

■ Operator’s Cab and Controls

Fully enclosed modular steel compartment is independently mounted and insulated to protect against vibration and noise.

- All tinted/tempered safety glass
- Sliding entry door and front window
- Swing up roof window with wiper
- Door and window locks
- Heater with circulating fan
- Air conditioner
- Sun visor
- Engine instrumentation panel (tachometer, voltmeter, engine oil pressure, engine water temperature, fuel level, hydraulic oil temperature, and service monitor system)
- Mechanical drum rotation indicators
- Six way adjustable seat
- Dry chemical fire extinguisher
- Hand and foot throttle
- Single axis, armchair control levers
- Swing lever with swing brake and horn located on handle
- Bubble type level

(continued on page 7)

LS-138H II Load Hoisting Performance

Available line speed and line pull – based on Isuzu A-6SDITQB at 2,000 rpm full load speed. Line pulls are not based on wire rope strength. See wire rope capacity chart for maximum permissible single part of line working loads.

| Rope Layer | Front or Rear Drum – 7/8" (22.22 mm) Wire Rope | | | | | | | | | | | |
|------------|--|--------|--------------------|-------|----------------------|-------|----------------|-----|-------|----|-------|-----|
| | Maximum Line Pull | | No Load Line Speed | | Full Load Line Speed | | Pitch Diameter | | Layer | | Total | |
| | lbs. | kg | ft/min. | m/min | ft/min. | m/min | in. | mm | ft. | m | ft. | m |
| 1 | 32,430 | 14 710 | 298 | 91 | 113 | 35 | 18.5 | 470 | 100 | 30 | 100 | 30 |
| 2 | 29,630 | 13 440 | 326 | 99 | 124 | 38 | 20.3 | 516 | 109 | 33 | 209 | 64 |
| 3 | 27,274 | 12 372 | 354 | 108 | 135 | 41 | 22.0 | 559 | 119 | 36 | 327 | 100 |
| 4 | 25,266 | 11 461 | 382 | 116 | 145 | 44 | 23.8 | 605 | 128 | 39 | 455 | 139 |
| 5 | 23,533 | 10 674 | 410 | 125 | 156 | 48 | 25.5 | 648 | 137 | 42 | 593 | 181 |
| 6 | 22,023 | 9 989 | 438 | 134 | 167 | 51 | 27.3 | 693 | 147 | 45 | 740 | 225 |
| 7 | – | – | – | – | – | – | 29.0 | 737 | 156 | 48 | 896 | 273 |

| Rope Layer | Boom Hoist Drum – 5/8" (15.88 mm) Wire Rope | | | | | | | | | | | |
|------------|---|-------|--------------------|-------|----------------------|-------|----------------|-----|-------|----|-------|-----|
| | Maximum Line Pull | | No Load Line Speed | | Full Load Line Speed | | Pitch Diameter | | Layer | | Total | |
| | lbs. | kg | ft/min. | m/min | ft/min. | m/min | in. | mm | ft. | m | ft. | m |
| 1 | 17 832 | 8 089 | 196 | 60 | 109 | 33 | 13.2 | 336 | 48 | 15 | 48 | 15 |
| 2 | 16 282 | 7 385 | 214 | 65 | 119 | 36 | 14.5 | 368 | 52 | 16 | 100 | 31 |
| 3 | 14 979 | 6 794 | 233 | 71 | 130 | 40 | 15.7 | 400 | 57 | 17 | 157 | 48 |
| 4 | 13 869 | 6 291 | 251 | 77 | 140 | 43 | 17.0 | 432 | 61 | 19 | 218 | 67 |
| 5 | 12 913 | 5 857 | 270 | 82 | 151 | 46 | 18.3 | 464 | 66 | 20 | 284 | 87 |
| 6 | 11 080 | 5 479 | 289 | 88 | 161 | 49 | 19.5 | 496 | 70 | 21 | 355 | 108 |
| 7 | 11 348 | 5 147 | 307 | 94 | 171 | 52 | 20.8 | 528 | 75 | 23 | 430 | 131 |
| 8 | 10 699 | 4 853 | 326 | 99 | 182 | 55 | 22.0 | 560 | 80 | 24 | 509 | 155 |

| Rope Layer | Optional Third Drum – 5/8" (15.88 mm) Wire Rope | | | | | | | | | | | |
|------------|---|-------|--------------------|-------|----------------------|-------|----------------|-----|-------|----|-------|-----|
| | Maximum Line Pull | | No Load Line Speed | | Full Load Line Speed | | Pitch Diameter | | Layer | | Total | |
| | lbs. | kg | ft/min. | m/min | ft/min. | m/min | in. | mm | ft. | m | ft. | m |
| 1 | 15,041 | 6 822 | 157 | 48 | 143 | 44 | 11.25 | 286 | 57 | 17 | 57 | 17 |
| 2 | 13,537 | 6 140 | 175 | 53 | 159 | 48 | 12.50 | 318 | 64 | 20 | 121 | 37 |
| 3 | 12,307 | 5 582 | 192 | 59 | 175 | 53 | 13.75 | 349 | 71 | 22 | 192 | 59 |
| 4 | 11,282 | 5 117 | 210 | 64 | 191 | 58 | 15.00 | 381 | 77 | 23 | 269 | 82 |
| 5 | 10,414 | 4 724 | 228 | 69 | 207 | 63 | 16.25 | 413 | 83 | 25 | 352 | 107 |
| 6 | 9,671 | 4 387 | 245 | 75 | 223 | 68 | 17.50 | 445 | 90 | 27 | 442 | 135 |

| Wire Rope Application | Diameter | | Length | | Type | Maximum Permissible Load | |
|-----------------------|----------|-------|--------|-----|------|--------------------------|--------|
| | in | mm | ft | m | | lb | kg |
| Boom Hoist | 5/8 | 15.88 | 610 | 186 | W | 11,770 | 5 339 |
| Front Hoist | 7/8 | 22.22 | 700 | 213 | DB | 22,740 | 10 315 |
| Rear Hoist (Optional) | 7/8 | 22.22 | 540 | 165 | RB | 17,520 | 7 947 |
| Rear Hoist (Optional) | 7/8 | 22.22 | 700 | 213 | DB | 22,740 | 10 315 |
| Third Drum (Optional) | 5/8 | 15.88 | 385 | 117 | ZB | 11,080 | 5 026 |
| Third Drum (Optional) | 5/8 | 15.88 | 385 | 117 | WB | 13,650 | 6 192 |

| Rope Type | Description |
|-----------|--|
| DB | 6 x 26 (6 X 19 Class) – Warrington Seale – Extra Improved Plow Steel – Preformed – Right Lay – Regular Lay – I.W.R.C. |
| RB* | 18 x 19 (19 x 19 Class) – Rotation Resistant – Extra Improved Plow Steel – Preformed – Right Lay – Regular Lay – Swaged – SF=5.1 |
| ZB | 36 x 7 – Non-rotating – Extra Improved Plow Steel – Right Lay – Regular Lay – S.F.=5.1 |
| WB | 8 Strand – Regular Lay |
| W | 6 x 26 (6 x 19 Class) – Warrington Seale – Extra Improved Plow Steel – Preformed – Right Lay – Alternate Lay |

* – Use of swivel ball is not recommended.

Revolving Upperstructure (continued from page 5)

■ Load Indicator/ Rated Capacity Limiter

Standard Equipment – PAT EI-65 load indicator provides two lineriders, angle sensor, computer, display, and anti-two block equipment to provide the following information.

- Boom length & angle.
- Jib length & angle.
- Load on hook.
- Load radius.
- Tip height.
- Anti-two block warning & function limiters.
- Operation mode.
- Operator settable alarms provide audio/visual warning.

Optional Equipment – PAT DS-350 rated capacity limiter provides all the same equipment and features of the standard EI-65 in conjunction with the following features.

- Provides an audio/visual warning when the load on hook is within 90% of the cranes rated load.
- Provides an audio/visual warning and limits functions when the load on hook is at 100% of the cranes rated load.

Note: The DS-350 function limiters are activated for anti-two block and overload conditions. These limiters are designed to prevent hoist up on front and rear drums and boom down.

■ Additional Equipment – *Standard*

- 57.88" (1.47 m) outside diameter turntable bearing.
- Front, right, & left side removable catwalks.
- 77 US Gallons (291.5 L) fuel tank (usable quantity).
- Machine lifting links.

■ Additional Equipment – *Optional*

- Rud-o-matic® model 1248 tagline winder for angle boom (double barrel, spring wound, drum type).
- Rud-o-matic® model 648 tagline winder for tube boom.
- Full revolving type Fairleader with barrel, sheaves, and guide rollers.

Lower Structure

■ Lower Frame

All welded box construction frame with precision-machined surfaces for turntable bearing and rotating joint.

- 8'-10.7" (2.71 m) overall width.
- 11'-11" (3.63 m) overall length.

■ Treadmembers

All welded, precision-machined, steel frames can be hydraulically extended and retracted by a hydraulic cylinder mounted in the lower frame.

- 14' (4.27 m) extended gauge.
- 8'-11" (2.72 m) retracted gauge.
- 20'-2" (6.15 m) overall length.
- 36" (0.91 m) wide track shoes.
- 11 sealed (oil filled) track rollers per treadmember.
- Sealed (oil filled) idler and drive planetaries.
- Compact travel drives.
- Hydraulic self adjusting tracks.

Travel and Steering – Each treadmember contains a pilot controlled, bi-directional, axial piston motor and a planetary gear reduction unit to provide positive control under all load conditions.

- Individual control provides smooth, precise maneuverability including full-counter-rotation.
- Spring applied, hydraulically released disc type brake controlled automatically.
- Maximum travel speed is 1.0 mph (1.7 km/h) in high speed and 0.6 mph (1 km/h) in low speed.
- Designed to 30% gradeability.

Lifting Capacities

Lattice Boom Crawler Crane

LS-138H II

80-ton (72.57 metric ton)

HYLAB Series

Tube Boom Capacities

40' – 200' (12.19 – 60.96 m)

24' (7.31 m) Live Mast

- Extended/Retracted Side Frames

20' (6.10 m) Base Section

- Extended/Retracted Side Frames

5' (1.52m) Tip Extension

Duty Cycle Capacities

- 40' – 70' (12.19 – 21.34 m) Tube Boom
- Extended Side Frames
- "A" Counterweight

Tube Boom Capacities

- 40' – 200' (12.19 – 60.96 m) Tube Boom
- 54" (1.37 m) Wide x 44" (1.12 m) Deep Boom
- 20' (6.10 m) Open Throat Top Section
- 24' (7.31 m) Live Mast
- Extended / Retracted Side Frames
- Over End Blocked Capacities
- "AB", "A", or "0" Counterweight Options
- 20' 2" (6.15 m) Crawler Length

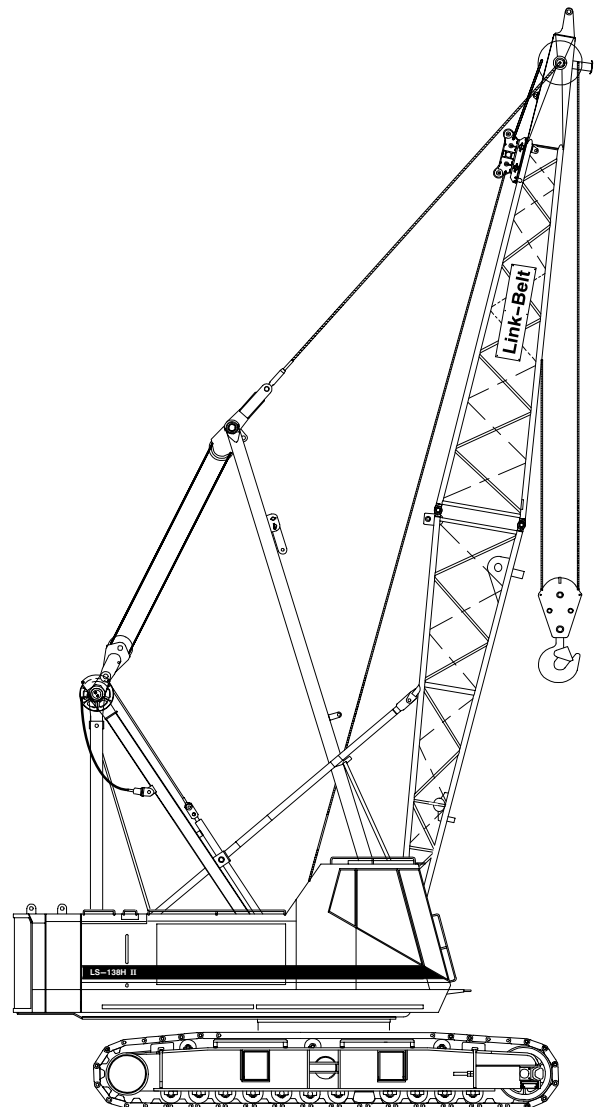

CAUTION: This material is supplied for reference use only. Operator must refer to in-cab Crane Rating Manual to determine allowable machine lifting capacities and operating procedures.



WARNING

READ AND UNDERSTAND THE OPERATOR'S AND SAFETY MANUALS AND THE FOLLOWING INSTRUCTIONS AND CHART VALUES BEFORE OPERATING THE CRANE. OPERATION WHICH DOES NOT FOLLOW THESE INSTRUCTIONS MAY RESULT IN AN ACCIDENT.

OPERATING INSTRUCTIONS

GENERAL:

1. Rated lifting capacities in pounds as shown on lift charts pertain to this crane as originally manufactured and normally equipped. Modifications to the crane or use of optional equipment other than that specified can result in a reduction of capacity.
2. Construction equipment can be dangerous if improperly operated or maintained. Operation and maintenance of this crane must be in compliance with the information in the Operator's, Parts, and Safety Manuals supplied with this crane. If these manuals are missing, order replacements through the distributor.
3. The operator and other personnel associated with this crane shall read and fully understand the latest applicable American National Standards Institute (ANSI) safety standards for cranes.
4. All capacities listed in this book are in compliance with ASME/ANSI B30.5c-1998, SAE J987-April 1994, and SAE J765-October 1990.

LIFT CRANE OPERATION:

1. Capacities shown are in pounds and are not more than 75% of the tipping loads with the crane standing level on firm supporting surface. A deduction must be made from these capacities for weight of hook block, hook ball, sling, grapple, load weighing device, etc. When using main hook while jib is attached, reduce capacities by values shown on Capacity Deductions For Lifting Off Main Boom Hook With Jib Installed. When using main hook while 5ft. tip extension is attached, reduce capacities by values shown on Capacity Deductions For Lifting Off Main Boom Hook With 5ft. Tip Extension Installed. See Operator's Manual for all limitations when raising or lowering attachment.
2. The crane capacities in the shaded areas are based on structural strength. The crane capacities in the non-shaded areas are based on stability ratings.

3. For recommended reeving, parts of line, wire rope type, and wire rope inspection, see Wire Rope Capacity chart, Operator's Manual, and Parts Manual.
4. Load ratings in this Crane Rating Manual are based on freely suspended loads and make no allowances for such factors as the effect of the wind, ground conditions, and operating speeds. The operator shall therefore reduce load ratings in order to take these conditions into account.
5. Rated lifting capacities do not account for the effects of wind on a suspended load or boom. Lifting capacities should be considered acceptable for wind speeds less than 20 mph and appropriately reduced for wind speeds greater than 20 mph. Extreme caution should be used when lifting heavy loads or loads with large wind sail area under high wind conditions (over 20 mph).
6. The 24ft. live mast must be used for all capacities in this Crane Rating Manual.
7. The least stable rated condition is over the side.
8. Booms must be erected and lowered over the end.
9. Do not operate at radii and boom lengths where the Crane Rating Manual lists no capacity. Do not use longer booms or jibs than those listed in this Crane Rating Manual. Any of the above can cause a tipping condition, or boom and jib failure.
10. These capacities apply only to the crane as originally manufactured and normally equipped by Link-Belt Construction Equipment Company.

FOR OVER END CAPACITIES ONLY

1. These capacities can be lifted over either end with the crane standing level on a firm supporting surface with adequate blocking placed under the tread member sprockets/idlers, to prevent rocking.
2. Do not travel with a load.

WIRE ROPE CAPACITY

| Parts of Line | 7/8" | | 5/8" | | Notes |
|---|---|-----------|-----------|-----------|---|
| | Type "DB" | Type "RB" | Type "ZB" | Type "WB" | |
| 1 | 22,700 | 17,520 * | 11,000 ** | 13,650 * | Capacities shown are in pounds and working loads must not exceed the ratings on the capacity charts in this Crane Rating Manual. Study Operator's Manual for wire rope inspection procedures. |
| 2 | 45,400 | 35,040 | 22,000 | 27,310 | |
| 3 | 68,100 | 52,560 | 33,000 | 40,970 | |
| 4 | 90,800 | 70,080 | 44,000 | 54,620 | |
| 5 | 113,500 | 87,600 | 55,000 | 68,280 | |
| 6 | 136,200 | 105,120 | 66,000 | 81,940 | |
| 7 | 158,900 | 122,640 | 77,000 | 95,600 | |
| 8 | 181,600 | 140,160 | 88,000 | 109,250 | |
| LBCE Type | Description | | | | |
| DB | 6 x 26 (6 x 19 Class) – Warrington Seale – Extra Improved Plow Steel – Preformed – Right Lay – Regular Lay – I.W.R.C. | | | | |
| RB | 19 x 19 Rotation Resistant– Extra Extra Improved Plow Steel – Preformed – Right Lay – Regular Lay. Swaged – SF = 5:1 | | | | |
| ZB | 36 x 7 Class – Non–Rotating – Extra Improved Plow Steel – Right Lay – Regular Lay – S.F. = 5:1 | | | | |
| WB | 8 Strand – Regular Lay | | | | |
| * Use of swivel end with 1 part of line is not recommended. | | | | | |
| ** Swivel end is recommended for operation with 1 part of line. | | | | | |

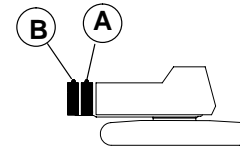

LIFTOFF CAPABILITIES

| Counterweight (Side Frames) | Over End | |
|-----------------------------|-------------------|------------------------------------|
| | Maximum Boom Feet | Maximum Boom + Jib Feet |
| NO (RETRACTED) | 90 | N/A |
| NO (EXTENDED) | 120 | N/A |
| A (RETRACTED) | 140 | N/A |
| A (EXTENDED) | 170 | N/A |
| AB (EXTENDED) See Note 6 | 200 | 180 + 60 190 + 30 See Note 6 |

| Counterweight (Side Frames) | Over Side | |
|-----------------------------|-------------------|-------------------------|
| | Maximum Boom Feet | Maximum Boom + Jib Feet |
| NO (RETRACTED) | 90 | N/A |
| NO (EXTENDED) | 120 | N/A |
| A (RETRACTED) | 140 | N/A |
| A (EXTENDED) | 170 | N/A |
| AB (EXTENDED) | 200 | 170 + 60 |

WORKING AREAS

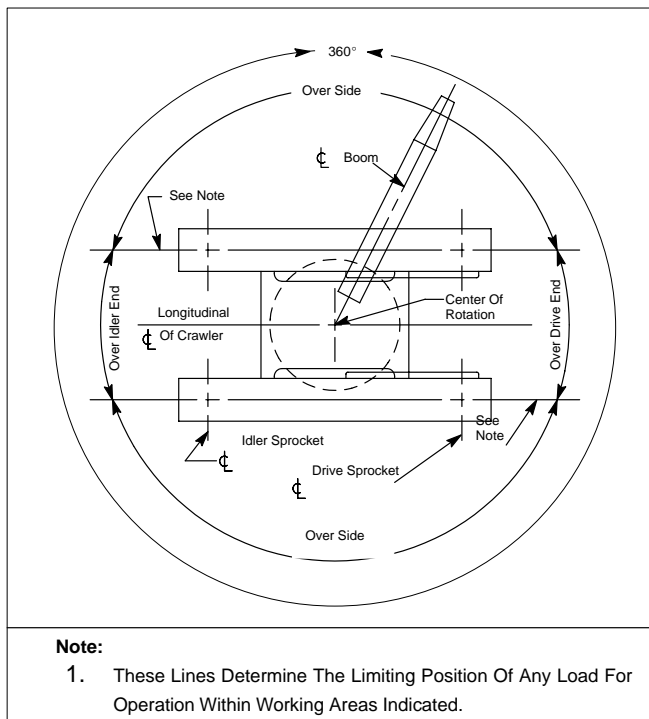

NOTES:

- Booms should be erected or lowered over the end with no load if possible – hook block on ground. (See Note 6).
- Crane on firm and level surface.
- Open throat booms 190' and 200' in length require mid-point suspension pendants.
- Boom and jib combination of 190' + 30' does require mid-point suspension pendants.
- Boom and jib combination of 180' + 60' does not require mid-point suspension pendants.
- For Maximum Boom + Jib Combinations only – Adequate blocking must be placed under The side frame sprockets/idlers to prevent rocking. (Lift Off Over End only).

CAPACITY DEDUCTIONS FOR LIFTING OFF MAIN BOOM HOOK WITH JIB INSTALLED (OPEN THROAT BOOM ONLY)

When using main boom hook, while jib is attached, reduce boom capacities by the values in the following chart:

| Jib Length (ft) | Capacity Deduction (lbs) |
|-----------------|--------------------------|
| 30 | 2,000 |
| 45 | 2,400 |
| 60 | 3,200 |

CAPACITY DEDUCTIONS FOR LIFTING OFF MAIN BOOM HOOK WITH 5 FOOT TIP EXTENSION INSTALLED

When using main boom hook, while 5 foot tip extension is attached, reduce boom capacities by the values in the following chart:

| Tip Extension (ft) | Capacity Deduction (lbs) |
|--------------------|--------------------------|
| 5 | 1,100 |

20' BASE SECTION CYLINDER LIFTING CAPACITIES (WITHOUT COUNTERWEIGHT INSTALLED)

| Base Section Cylinders | | Side Frames Extended (lb) | Side Frames Retracted (lb) |
|------------------------|-------------|---------------------------|----------------------------|
| Radius (ft) | Angle (deg) | | |
| 15 | 55.0 | 26,500 | 26,500 |
| 16 | 50.9 | 26,500 | 26,500 |
| 17 | 46.4 | 26,500 | 26,100 |
| 18 | 41.6 | 26,500 | 23,900 |
| 19 | 36.0 | 26,500 | 22,000 |
| 20 | 29.5 | 26,500 | 20,300 |
| 21 | 20.6 | 26,500 | 18,700 |

NOTES:

1. Rated capacities for 360° rotation.
2. Boom base section supported by make up pendants.
3. Lifting any load with one cylinder is prohibited. Rated capacities are for lifting loads with both cylinders.
4. Gantry can be either in the raised or lowered position when lifting loads with the cylinders in the base section. When the gantry is in the lowered position the backstay links must be pinned.
5. Do not raise boom higher than 55° angle.
6. Do not lower live mast below 3° angle with gantry in lowered position.

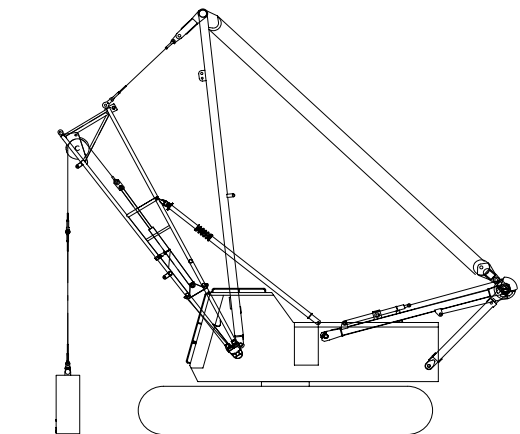

LIVE MAST LIFTING CAPACITIES (WITHOUT COUNTERWEIGHT INSTALLED)

| Live Mast | | Side Frames Extended (lb) | Side Frames Retracted (lb) |
|-------------|-------------|---------------------------|----------------------------|
| Radius (ft) | Angle (deg) | | |
| 10 | 73.7 | 60,000 | 60,000 |
| 11 | 71.2 | 60,000 | 51,600 |
| 12 | 68.7 | 60,000 | 44,600 |
| 13 | 66.1 | 60,000 | 39,200 |
| 14 | 63.5 | 60,000 | 34,900 |
| 15 | 60.8 | 59,400 | 31,500 |
| 16 | 58.0 | 52,700 | 28,600 |
| 17 | 55.1 | 47,400 | 26,200 |
| 18 | 52.2 | 43,000 | 24,200 |
| 19 | 49.1 | 39,300 | 22,500 |
| 20 | 45.8 | 36,200 | 20,900 |
| 21 | 42.4 | 33,500 | 19,600 |
| 22 | 38.8 | 31,200 | 18,400 |
| 23 | 34.8 | 29,200 | 17,300 |
| 24 | 30.3 | 27,400 | 16,400 |

NOTES:

1. Refer to the Operator's Manual.
2. Live mast backstops must be in position and operative.
3. Use rear hoist drum only. Reeve hoist line to drum over live mast cross member.
4. Reeve hoist rope with three (3) parts of 7/8" diameter wire rope.
5. The crane shall be leveled on a firm supporting surface.
6. Capacities are based on 75% stability.
7. See Crane Assembly Component Weights chart for weight of components for crane assembly.
8. Rated capacities for 360° rotation.
9. Gantry can be either in the raised or lowered position when lifting loads with the live mast. When the gantry is in the lowered position the backstay links must be pinned.
10. Do not lower live mast below 3° angle with gantry in lowered position.

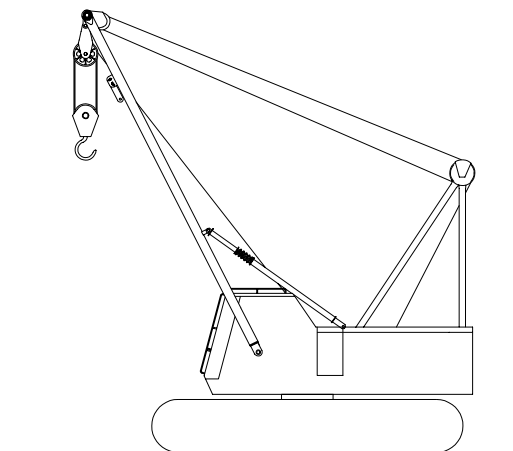

MAXIMUM ALLOWABLE CAPACITIES FOR 5 FOOT TIP EXTENSION

LIFTING CAPACITY TO BE THE SMALLEST OF THE FOLLOWING VALUES:

1. 18,000 lb (Maximum).
2. The standard crane lift capacity minus 1,100 lb for the boom length, tip extension load radius, and counterweight configuration in use on the crane.

NOTES:

1. All notes are to be adhered to as listed on the standard lift crane capacity charts .
2. Reduce the main boom lift capacities by 1,100 lb when the tip extension is installed.
3. The maximum boom length on which the tip extension can be installed is 150'.
4. Do not lift or suspend a load from the boom tip extension and main boom at the same time.

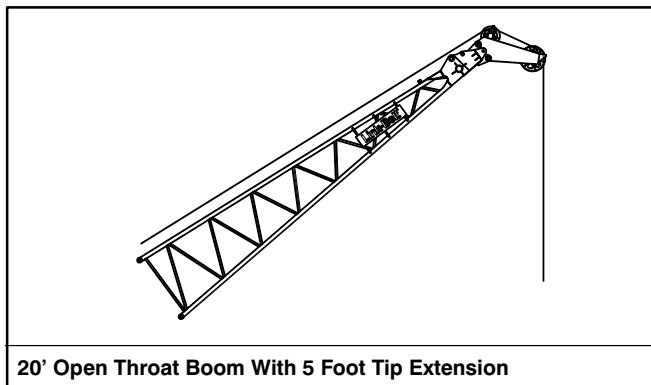

DUTY CYCLE NOTES FOR TUBULAR BOOM

1. The capacities included in this chart are the maximum allowable, and are based on machine standing level on firm supporting surface under ideal job conditions.
2. Capacities are based on 75% of minimum tipping loads for dragline; 67.5% for clamshell.
3. Capacities are maximum recommended by PCSA Standard #4. User must make allowances for soft or uneven supporting surfaces, rapid cycle operations, bucket suction or other unfavorable conditions which may require smaller buckets for most efficient operation.
4. Weight of bucket, plus load must not exceed these capacities.
5. Dragline operation is not recommended with boom angles less than 35°.
6. Boom length for dragline/clamshell attachment operation should not exceed 70'.
7. Retractable high gantry must be fixed in raised position for all capacities on this chart.
8. These capacities apply to the machine as originally manufactured and normally equipped by Link-Belt Construction Equipment Company.

DUTY CYCLE CAPACITIES TUBULAR BOOM

| Boom Length (ft) | Load Radius (ft) | Boom Angle (deg) | Side Frames Extended – "A" Counterweight Only (All capacities listed are in pounds) | |
|------------------|------------------|------------------|---|------------------|
| | | | Dragline | Clamshell/Magnet |
| 40 | 15 | 73.0 | — | 15,800 |
| 40 | 20 | 65.3 | — | 15,800 |
| 40 | 25 | 57.1 | 15,800 | 15,800 |
| 40 | 30 | 48.1 | 15,800 | 15,800 |
| 40 | 35 | 37.5 | 15,800 | 15,800 |
| 40 | 40 | 23.4 | — | 15,800 |
| 50 | 20 | 70.5 | — | 15,800 |
| 50 | 25 | 64.3 | — | 15,800 |
| 50 | 30 | 57.7 | 15,800 | 15,800 |
| 50 | 35 | 50.6 | 15,800 | 15,800 |
| 50 | 40 | 42.7 | 15,800 | 15,800 |
| 50 | 50 | 20.9 | — | 15,800 |
| 60 | 25 | 68.8 | — | 15,800 |
| 60 | 30 | 63.6 | — | 15,800 |
| 60 | 35 | 58.1 | 15,800 | 15,800 |
| 60 | 40 | 52.3 | 15,800 | 15,800 |
| 60 | 50 | 38.9 | 15,800 | 15,800 |
| 60 | 60 | 19.0 | — | 11,700 |
| 70 | 25 | 71.9 | — | 15,800 |
| 70 | 30 | 67.6 | — | 15,800 |
| 70 | 35 | 63.1 | — | 15,800 |
| 70 | 40 | 58.4 | 15,800 | 15,800 |
| 70 | 50 | 48.1 | 15,800 | 15,800 |
| 70 | 60 | 35.9 | 13,000 | 11,700 |
| 70 | 70 | 17.6 | — | 9,300 |

WORKING RANGE DIAGRAM

40' TO 200' OPEN THROAT BOOM

Maximum Boom Angle
See Note 2.

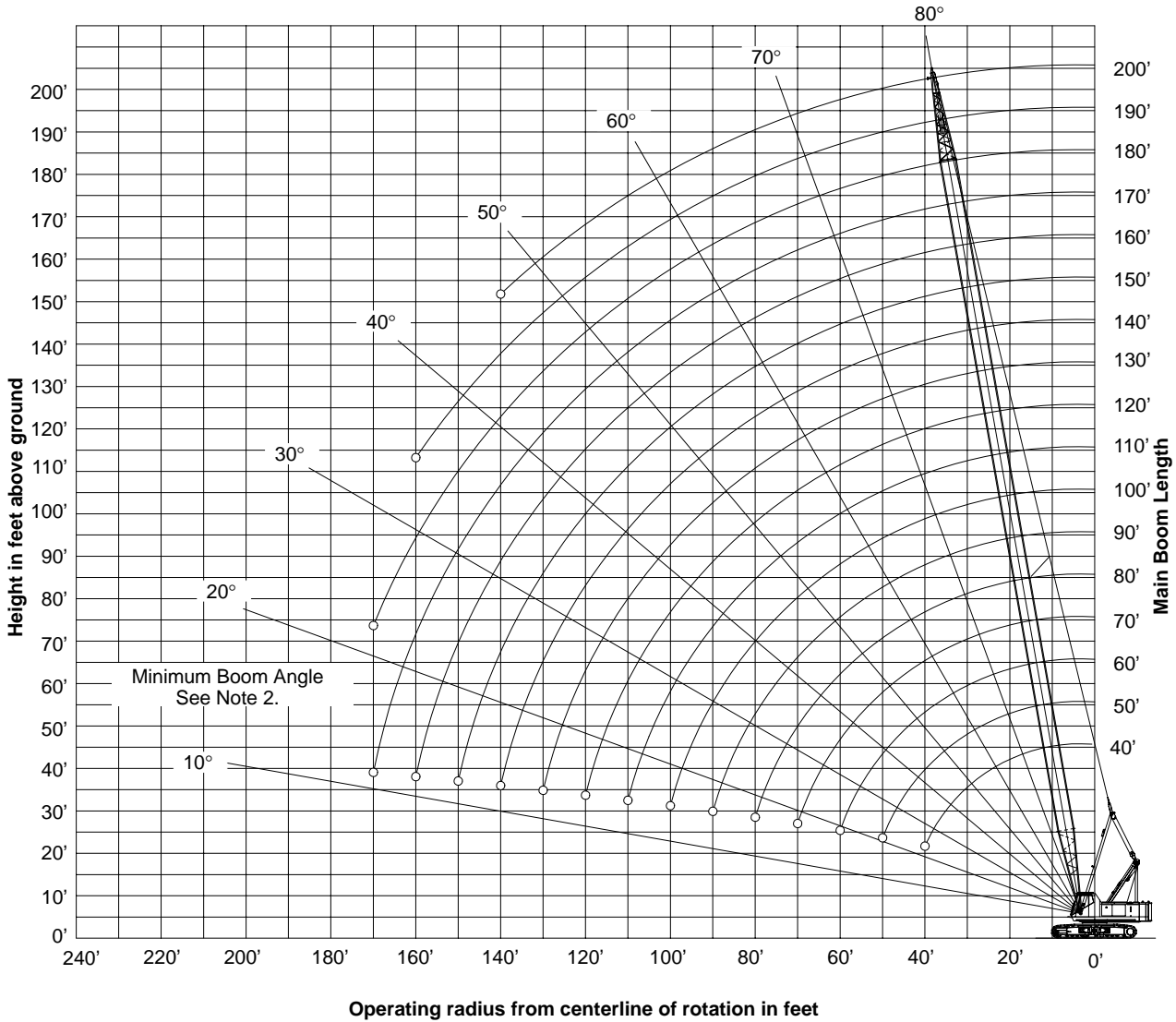

Minimum Boom Angle
See Note 2.

Notes:

1. Boom geometry shown is for unloaded condition and crane standing level on firm supporting surface. Boom deflection, subsequent radius and boom angle change must be accounted for when applying load to hook.
2. Maximum and minimum boom angles are equal to the values listed in the capacity chart for each boom length.

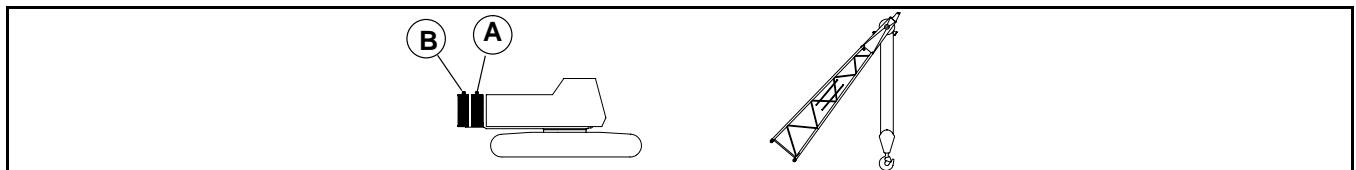

| MAIN BOOM CAPACITIES – 40 FT OPEN THROAT TUBE BOOM | | | | | | | |
|--|------------------|------------------|----------------------|-------------|-------------|-----------------------|-------------|
| Load Radius (Ft.) | Boom Angle (deg) | Over End Blocked | 360° Rotation | | | | |
| | | | Side Frames Extended | | | Side Frames Retracted | |
| | | | AB CTWT (lb) | A CTWT (lb) | 0 CTWT (lb) | A CTWT (lb) | 0 CTWT (lb) |
| 9 | 81.8 | 160,000 | 160,000 | 160,000 | 160,000 | 143,300 | 77,200 |
| 10 | 80.3 | 160,000 | 160,000 | 160,000 | 153,200 | 116,900 | 62,800 |
| 11 | 78.9 | 160,000 | 160,000 | 157,600 | 123,000 | 98,600 | 52,700 |
| 12 | 77.4 | 160,000 | 160,000 | 145,300 | 98,100 | 85,100 | 45,300 |
| 13 | 75.9 | 151,900 | 151,900 | 134,800 | 81,500 | 74,800 | 39,700 |
| 14 | 74.5 | 141,600 | 141,600 | 118,600 | 69,500 | 66,600 | 35,200 |
| 15 | 73.0 | 132,600 | 132,600 | 103,500 | 60,500 | 60,000 | 31,500 |
| 16 | 71.5 | 124,700 | 124,700 | 91,800 | 53,500 | 54,500 | 28,500 |
| 17 | 69.9 | 117,600 | 117,600 | 82,300 | 47,900 | 49,900 | 26,000 |
| 18 | 68.4 | 111,300 | 108,700 | 74,600 | 43,300 | 46,000 | 23,900 |
| 19 | 66.9 | 105,600 | 99,500 | 68,200 | 39,400 | 42,600 | 22,000 |
| 20 | 65.3 | 100,400 | 91,600 | 62,700 | 36,200 | 39,700 | 20,400 |
| 25 | 57.1 | 80,200 | 65,400 | 44,500 | 25,300 | 29,200 | 14,600 |
| 30 | 48.1 | 60,900 | 50,500 | 34,100 | 19,100 | 22,900 | 11,100 |
| 35 | 37.5 | 48,800 | 40,900 | 27,400 | 15,100 | 18,600 | 8,700 |
| 40 | 23.4 | 40,500 | 34,100 | 22,700 | 12,200 | 15,400 | 7,000 |

| MAIN BOOM CAPACITIES – 70 FT OPEN THROAT TUBE BOOM | | | | | | | |
|--|------------------|------------------|----------------------|-------------|-------------|-----------------------|-------------|
| Load Radius (Ft.) | Boom Angle (deg) | Over End Blocked | 360° Rotation | | | | |
| | | | Side Frames Extended | | | Side Frames Retracted | |
| | | | AB CTWT (lb) | A CTWT (lb) | 0 CTWT (lb) | A CTWT (lb) | 0 CTWT (lb) |
| 14 | 81.2 | 129,700 | 129,700 | 119,600 | 70,600 | 67,100 | 35,700 |
| 15 | 80.4 | 126,800 | 126,800 | 104,400 | 61,400 | 60,400 | 32,000 |
| 16 | 79.5 | 124,100 | 124,100 | 92,600 | 54,300 | 54,900 | 28,900 |
| 17 | 78.7 | 117,100 | 117,100 | 83,000 | 48,600 | 50,300 | 26,400 |
| 18 | 77.9 | 110,800 | 109,400 | 75,200 | 43,900 | 46,300 | 24,200 |
| 19 | 77.0 | 105,200 | 100,000 | 68,700 | 40,000 | 42,900 | 22,300 |
| 20 | 76.2 | 100,000 | 92,100 | 63,200 | 36,700 | 39,900 | 20,600 |
| 25 | 71.9 | 80,200 | 65,700 | 44,800 | 25,600 | 29,400 | 14,800 |
| 30 | 67.6 | 61,200 | 50,800 | 34,400 | 19,400 | 23,000 | 11,300 |
| 35 | 63.1 | 49,100 | 41,100 | 27,700 | 15,300 | 18,700 | 8,900 |
| 40 | 58.4 | 40,800 | 34,400 | 23,000 | 12,500 | 15,600 | 7,100 |
| 50 | 48.1 | 30,100 | 25,600 | 16,800 | 8,800 | 11,400 | 4,800 |
| 60 | 35.9 | 23,600 | 20,100 | 13,000 | 6,400 | 8,700 | 3,300 |
| 70 | 17.6 | 19,100 | 16,300 | 10,300 | 4,800 | 6,800 | 2,200 |

| MAIN BOOM CAPACITIES – 50 FT OPEN THROAT TUBE BOOM | | | | | | | |
|--|------------------|------------------|----------------------|-------------|-------------|-----------------------|-------------|
| Load Radius (Ft.) | Boom Angle (deg) | Over End Blocked | 360° Rotation | | | | |
| | | | Side Frames Extended | | | Side Frames Retracted | |
| | | | AB CTWT (lb) | A CTWT (lb) | 0 CTWT (lb) | A CTWT (lb) | 0 CTWT (lb) |
| 11 | 81.1 | 159,900 | 159,900 | 157,300 | 123,900 | 99,000 | 53,100 |
| 12 | 80.0 | 159,900 | 159,900 | 145,100 | 98,900 | 85,500 | 45,700 |
| 13 | 78.8 | 151,700 | 151,700 | 134,600 | 82,100 | 75,100 | 40,000 |
| 14 | 77.6 | 141,500 | 141,500 | 119,100 | 70,000 | 66,900 | 35,500 |
| 15 | 76.4 | 132,500 | 132,500 | 104,000 | 61,000 | 60,300 | 31,800 |
| 16 | 75.3 | 124,600 | 124,600 | 92,200 | 53,900 | 54,800 | 28,800 |
| 17 | 74.1 | 117,500 | 117,500 | 82,700 | 48,300 | 50,200 | 26,200 |
| 18 | 72.9 | 111,200 | 109,100 | 75,000 | 43,600 | 46,200 | 24,100 |
| 19 | 71.7 | 105,500 | 99,800 | 68,500 | 39,800 | 42,800 | 22,200 |
| 20 | 70.5 | 100,300 | 91,900 | 63,000 | 36,500 | 39,900 | 20,600 |
| 25 | 64.3 | 80,200 | 65,600 | 44,700 | 25,500 | 29,400 | 14,800 |
| 30 | 57.7 | 61,100 | 50,700 | 34,300 | 19,300 | 23,000 | 11,300 |
| 35 | 50.6 | 49,000 | 41,100 | 27,600 | 15,300 | 18,700 | 8,900 |
| 40 | 42.7 | 40,700 | 34,400 | 22,900 | 12,400 | 15,600 | 7,200 |
| 50 | 20.9 | 30,000 | 25,500 | 16,800 | 8,700 | 11,400 | 4,800 |

| MAIN BOOM CAPACITIES – 80 FT OPEN THROAT TUBE BOOM | | | | | | | |
|--|------------------|------------------|----------------------|-------------|-------------|-----------------------|-------------|
| Load Radius (Ft.) | Boom Angle (deg) | Over End Blocked | 360° Rotation | | | | |
| | | | Side Frames Extended | | | Side Frames Retracted | |
| | | | AB CTWT (lb) | A CTWT (lb) | 0 CTWT (lb) | A CTWT (lb) | 0 CTWT (lb) |
| 15 | 81.6 | 116,800 | 116,800 | 104,500 | 61,600 | 60,400 | 32,000 |
| 16 | 80.9 | 114,600 | 114,600 | 92,700 | 54,400 | 54,900 | 28,900 |
| 17 | 80.1 | 111,400 | 111,400 | 83,100 | 48,700 | 50,300 | 26,300 |
| 18 | 79.4 | 109,300 | 109,300 | 75,300 | 44,000 | 46,300 | 24,100 |
| 19 | 78.7 | 104,900 | 100,100 | 68,800 | 40,100 | 42,900 | 22,200 |
| 20 | 77.9 | 99,800 | 92,200 | 63,300 | 36,700 | 39,900 | 20,600 |
| 25 | 74.2 | 80,000 | 65,700 | 44,800 | 25,600 | 29,400 | 14,700 |
| 30 | 70.5 | 61,200 | 50,700 | 34,400 | 19,300 | 22,900 | 11,200 |
| 35 | 66.6 | 49,000 | 41,100 | 27,600 | 15,300 | 18,600 | 8,800 |
| 40 | 62.7 | 40,700 | 34,300 | 22,900 | 12,400 | 15,500 | 7,100 |
| 50 | 54.3 | 30,100 | 25,500 | 16,800 | 8,700 | 11,300 | 4,700 |
| 60 | 44.8 | 23,500 | 20,000 | 12,900 | 6,400 | 8,600 | 3,200 |
| 70 | 33.5 | 19,100 | 16,300 | 10,300 | 4,800 | 6,700 | 2,100 |
| 80 | 16.5 | 15,900 | 13,500 | 8,300 | 3,600 | 5,300 | — |

| MAIN BOOM CAPACITIES – 60 FT OPEN THROAT TUBE BOOM | | | | | | | |
|--|------------------|------------------|----------------------|-------------|-------------|-----------------------|-------------|
| Load Radius (Ft.) | Boom Angle (deg) | Over End Blocked | 360° Rotation | | | | |
| | | | Side Frames Extended | | | Side Frames Retracted | |
| | | | AB CTWT (lb) | A CTWT (lb) | 0 CTWT (lb) | A CTWT (lb) | 0 CTWT (lb) |
| 12 | 81.6 | 149,600 | 149,600 | 144,800 | 99,300 | 85,600 | 45,900 |
| 13 | 80.7 | 146,400 | 146,400 | 134,400 | 82,500 | 75,300 | 40,100 |
| 14 | 79.7 | 141,200 | 141,200 | 119,400 | 70,400 | 67,000 | 35,600 |
| 15 | 78.7 | 132,300 | 132,300 | 104,200 | 61,300 | 60,400 | 31,900 |
| 16 | 77.8 | 124,400 | 124,400 | 92,400 | 54,200 | 54,900 | 28,900 |
| 17 | 76.8 | 117,400 | 117,400 | 82,900 | 48,500 | 50,300 | 26,300 |
| 18 | 75.8 | 111,100 | 109,300 | 75,100 | 43,800 | 46,300 | 24,200 |
| 19 | 74.8 | 105,400 | 99,900 | 68,700 | 39,900 | 42,900 | 22,300 |
| 20 | 73.8 | 100,200 | 92,100 | 63,200 | 36,600 | 39,900 | 20,600 |
| 25 | 68.8 | 80,200 | 65,700 | 44,800 | 25,600 | 29,400 | 14,800 |
| 30 | 63.6 | 61,200 | 50,800 | 34,400 | 19,400 | 23,000 | 11,300 |
| 35 | 58.1 | 49,100 | 41,100 | 27,700 | 15,300 | 18,700 | 8,900 |
| 40 | 52.3 | 40,800 | 34,400 | 23,000 | 12,500 | 15,600 | 7,200 |
| 50 | 38.9 | 30,100 | 25,600 | 16,800 | 8,800 | 11,400 | 4,800 |
| 60 | 19.0 | 23,600 | 20,100 | 13,000 | 6,400 | 8,700 | 3,300 |

| MAIN BOOM CAPACITIES – 90 FT OPEN THROAT TUBE BOOM | | | | | | | |
|--|------------------|------------------|----------------------|-------------|-------------|-----------------------|-------------|
| Load Radius (Ft.) | Boom Angle (deg) | Over End Blocked | 360° Rotation | | | | |
| | | | Side Frames Extended | | | Side Frames Retracted | |
| | | | AB CTWT (lb) | A CTWT (lb) | 0 CTWT (lb) | A CTWT (lb) | 0 CTWT (lb) |
| 16 | 81.9 | 104,700 | 104,700 | 92,700 | 54,500 | 54,900 | 28,900 |
| 17 | 81.2 | 102,800 | 102,800 | 83,200 | 48,700 | 50,200 | 26,300 |
| 18 | 80.6 | 101,200 | 101,200 | 75,300 | 44,000 | 46,200 | 24,100 |
| 19 | 79.9 | 99,600 | 99,600 | 68,800 | 40,100 | 42,800 | 22,200 |
| 20 | 79.3 | 97,700 | 92,200 | 63,300 | 36,700 | 39,800 | 20,500 |
| 25 | 76.0 | 79,800 | 65,700 | 44,800 | 25,600 | 29,300 | 14,700 |
| 30 | 72.7 | 61,200 | 50,700 | 34,300 | 19,300 | 22,800 | 11,100 |
| 35 | 69.4 | 49,000 | 41,000 | 27,500 | 15,200 | 18,500 | 8,700 |
| 40 | 65.9 | 40,700 | 34,200 | 22,800 | 12,300 | 15,400 | 6,900 |
| 50 | 58.7 | 30,000 | 25,400 | 16,700 | 8,600 | 11,200 | 4,600 |
| 60 | 50.9 | 23,500 | 19,900 | 12,800 | 6,300 | 8,500 | 3,100 |
| 70 | 42.2 | 19,000 | 16,200 | 10,200 | 4,700 | 6,600 | 2,000 |
| 80 | 31.5 | 15,800 | 13,400 | 8,300 | 3,500 | 5,200 | — |
| 90 | 15.5 | 13,400 | 11,300 | 6,800 | 2,600 | 4,100 | — |

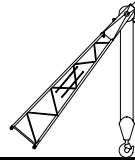
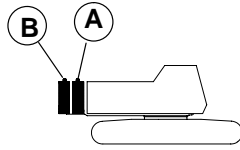

| MAIN BOOM CAPACITIES – 100 FT OPEN THROAT TUBE BOOM | | | | | | | | |
|---|------------------|------------------|----------------------|-----------|-------------|-----------------------|-------------|------------|
| Load Radius (Ft.) | Boom Angle (deg) | Over End Blocked | 360° Rotation | | | | | PROHIBITED |
| | | | Side Frames Extended | | | Side Frames Retracted | | |
| | | | AB CTWT (lb) | CTWT (lb) | A CTWT (lb) | 0 CTWT (lb) | A CTWT (lb) | |
| 18 | 81.5 | 93,400 | 93,400 | 75,300 | 44,000 | 46,200 | | |
| 19 | 81.0 | 92,000 | 92,000 | 68,800 | 40,000 | 42,700 | | |
| 20 | 80.4 | 89,400 | 89,400 | 63,200 | 36,700 | 39,700 | | |
| 25 | 77.5 | 79,600 | 65,600 | 44,700 | 25,500 | 29,200 | | |
| 30 | 74.5 | 61,100 | 50,600 | 34,200 | 19,200 | 22,700 | | |
| 35 | 71.5 | 48,900 | 40,900 | 27,400 | 15,100 | 18,400 | | |
| 40 | 68.5 | 40,600 | 34,100 | 22,700 | 12,200 | 15,300 | | |
| 50 | 62.1 | 29,900 | 25,300 | 16,600 | 8,500 | 11,100 | | |
| 60 | 55.4 | 23,400 | 19,800 | 12,700 | 6,200 | 8,400 | | |
| 70 | 48.2 | 18,900 | 16,100 | 10,100 | 4,600 | 6,500 | | |
| 80 | 39.9 | 15,700 | 13,300 | 8,100 | 3,400 | 5,100 | | |
| 90 | 29.9 | 13,300 | 11,200 | 6,700 | 2,500 | 4,000 | | |
| 100 | 14.7 | 11,400 | 9,500 | 5,500 | — | 3,100 | | |

| MAIN BOOM CAPACITIES – 130 FT OPEN THROAT TUBE BOOM | | | | | | | | |
|---|------------------|------------------|----------------------|-----------|-------------|-----------------------|-------------|------------|
| Load Radius (Ft.) | Boom Angle (deg) | Over End Blocked | 360° Rotation | | | | | PROHIBITED |
| | | | Side Frames Extended | | | Side Frames Retracted | | |
| | | | AB CTWT (lb) | CTWT (lb) | A CTWT (lb) | 0 CTWT (lb) | A CTWT (lb) | |
| 25 | 80.4 | 65,100 | 65,100 | 44,500 | — | 28,800 | | |
| 30 | 78.1 | 60,900 | 50,300 | 33,900 | — | 22,300 | | |
| 35 | 75.9 | 48,600 | 40,600 | 27,100 | — | 18,000 | | |
| 40 | 73.6 | 40,200 | 33,800 | 22,300 | — | 14,800 | | |
| 50 | 68.9 | 29,500 | 24,900 | 16,200 | — | 10,600 | | |
| 60 | 64.1 | 23,000 | 19,400 | 12,300 | — | 7,900 | | |
| 70 | 59.1 | 18,500 | 15,600 | 9,600 | — | 6,000 | | |
| 80 | 53.8 | 15,300 | 12,900 | 7,700 | — | 4,700 | | |
| 90 | 48.2 | 12,900 | 10,800 | 6,300 | — | 3,600 | | |
| 100 | 41.9 | 11,000 | 9,200 | 5,100 | — | 2,700 | | |
| 110 | 34.8 | 9,500 | 7,800 | 4,200 | — | 2,000 | | |
| 120 | 26.1 | 8,200 | 6,700 | 3,400 | — | — | | |
| 130 | 12.9 | 7,100 | 5,800 | 2,700 | — | — | | |

| MAIN BOOM CAPACITIES – 110 FT OPEN THROAT TUBE BOOM | | | | | | | | |
|---|------------------|------------------|----------------------|-----------|-------------|-----------------------|-------------|------------|
| Load Radius (Ft.) | Boom Angle (deg) | Over End Blocked | 360° Rotation | | | | | PROHIBITED |
| | | | Side Frames Extended | | | Side Frames Retracted | | |
| | | | AB CTWT (lb) | CTWT (lb) | A CTWT (lb) | 0 CTWT (lb) | A CTWT (lb) | |
| 25 | 78.6 | 77,100 | 65,500 | 44,600 | 25,400 | 29,000 | | |
| 30 | 75.9 | 61,000 | 50,500 | 34,100 | 19,100 | 22,600 | | |
| 35 | 73.2 | 48,800 | 40,800 | 27,300 | 15,000 | 18,200 | | |
| 40 | 70.5 | 40,500 | 34,000 | 22,600 | 12,100 | 15,100 | | |
| 50 | 64.9 | 29,800 | 25,200 | 16,400 | 8,400 | 10,900 | | |
| 60 | 59.0 | 23,200 | 19,700 | 12,600 | 6,000 | 8,200 | | |
| 70 | 52.7 | 18,800 | 15,900 | 9,900 | 4,400 | 6,400 | | |
| 80 | 45.8 | 15,600 | 13,200 | 8,000 | 3,300 | 5,000 | | |
| 90 | 38.0 | 13,200 | 11,100 | 6,500 | 2,400 | 3,900 | | |
| 100 | 28.4 | 11,300 | 9,400 | 5,400 | — | 3,000 | | |
| 110 | 14.0 | 9,700 | 8,100 | 4,400 | — | 2,300 | | |

| MAIN BOOM CAPACITIES – 140 FT OPEN THROAT TUBE BOOM | | | | | | | | |
|---|------------------|------------------|----------------------|-----------|-------------|-----------------------|-------------|------------|
| Load Radius (Ft.) | Boom Angle (deg) | Over End Blocked | 360° Rotation | | | | | PROHIBITED |
| | | | Side Frames Extended | | | Side Frames Retracted | | |
| | | | AB CTWT (lb) | CTWT (lb) | A CTWT (lb) | 0 CTWT (lb) | A CTWT (lb) | |
| 25 | 81.1 | 60,000 | 60,000 | 44,400 | — | 28,700 | | |
| 30 | 79.0 | 56,700 | 50,200 | 33,800 | — | 22,200 | | |
| 35 | 76.9 | 48,500 | 40,400 | 27,000 | — | 17,800 | | |
| 40 | 74.8 | 40,100 | 33,600 | 22,200 | — | 14,700 | | |
| 50 | 70.5 | 29,400 | 24,800 | 16,000 | — | 10,500 | | |
| 60 | 66.1 | 22,800 | 19,200 | 12,100 | — | 7,800 | | |
| 70 | 61.5 | 18,400 | 15,500 | 9,500 | — | 5,900 | | |
| 80 | 56.8 | 15,200 | 12,700 | 7,600 | — | 4,500 | | |
| 90 | 51.7 | 12,700 | 10,600 | 6,100 | — | 3,400 | | |
| 100 | 46.3 | 10,800 | 9,000 | 4,900 | — | 2,600 | | |
| 110 | 40.3 | 9,300 | 7,700 | 4,000 | — | — | | |
| 120 | 33.5 | 8,000 | 6,600 | 3,200 | — | — | | |
| 130 | 25.2 | 7,000 | 5,600 | 2,600 | — | — | | |
| 140 | 12.4 | 6,100 | 4,800 | 2,000 | — | — | | |

| MAIN BOOM CAPACITIES – 120 FT OPEN THROAT TUBE BOOM | | | | | | | | |
|---|------------------|------------------|----------------------|-----------|-------------|-----------------------|-------------|------------|
| Load Radius (Ft.) | Boom Angle (deg) | Over End Blocked | 360° Rotation | | | | | PROHIBITED |
| | | | Side Frames Extended | | | Side Frames Retracted | | |
| | | | AB CTWT (lb) | CTWT (lb) | A CTWT (lb) | 0 CTWT (lb) | A CTWT (lb) | |
| 25 | 79.6 | 71,600 | 65,500 | 44,600 | 25,400 | 28,900 | | |
| 30 | 77.1 | 61,000 | 50,400 | 34,000 | 19,000 | 22,500 | | |
| 35 | 74.7 | 48,700 | 40,700 | 27,200 | 14,900 | 18,100 | | |
| 40 | 72.2 | 40,400 | 33,900 | 22,500 | 12,000 | 15,000 | | |
| 50 | 67.1 | 29,700 | 25,100 | 16,300 | 8,200 | 10,800 | | |
| 60 | 61.8 | 23,100 | 19,500 | 12,400 | 5,900 | 8,100 | | |
| 70 | 56.2 | 18,700 | 15,800 | 9,800 | 4,300 | 6,200 | | |
| 80 | 50.3 | 15,500 | 13,000 | 7,900 | 3,100 | 4,800 | | |
| 90 | 43.7 | 13,000 | 10,900 | 6,400 | 2,200 | 3,700 | | |
| 100 | 36.3 | 11,100 | 9,300 | 5,200 | — | 2,900 | | |
| 110 | 27.2 | 9,600 | 8,000 | 4,300 | — | 2,200 | | |
| 120 | 13.4 | 8,300 | 6,800 | 3,500 | — | — | | |

| MAIN BOOM CAPACITIES – 150 FT OPEN THROAT TUBE BOOM | | | | | | | | |
|---|------------------|------------------|----------------------|-----------|-------------|-----------------------|-------------|------------|
| Load Radius (Ft.) | Boom Angle (deg) | Over End Blocked | 360° Rotation | | | | | PROHIBITED |
| | | | Side Frames Extended | | | Side Frames Retracted | | |
| | | | AB CTWT (lb) | CTWT (lb) | A CTWT (lb) | 0 CTWT (lb) | A CTWT (lb) | |
| 25 | 81.7 | 55,100 | 55,100 | 44,300 | — | — | | |
| 30 | 79.7 | 52,200 | 50,000 | 33,700 | — | — | | |
| 35 | 77.8 | 48,400 | 40,300 | 26,800 | — | — | | |
| 40 | 75.8 | 40,000 | 33,500 | 22,100 | — | — | | |
| 50 | 71.9 | 29,200 | 24,600 | 15,900 | — | — | | |
| 60 | 67.8 | 22,700 | 19,100 | 12,000 | — | — | | |
| 70 | 63.6 | 18,200 | 15,300 | 9,300 | — | — | | |
| 80 | 59.2 | 15,000 | 12,600 | 7,400 | — | — | | |
| 90 | 54.7 | 12,600 | 10,500 | 5,900 | — | — | | |
| 100 | 49.9 | 10,700 | 8,800 | 4,800 | — | — | | |
| 110 | 44.6 | 9,100 | 7,500 | 3,800 | — | — | | |
| 120 | 38.9 | 7,900 | 6,400 | 3,100 | — | — | | |
| 130 | 32.4 | 6,800 | 5,500 | 2,400 | — | — | | |
| 140 | 24.3 | 5,900 | 4,700 | — | — | — | | |
| 150 | 12.0 | 5,100 | 4,000 | — | — | — | | |

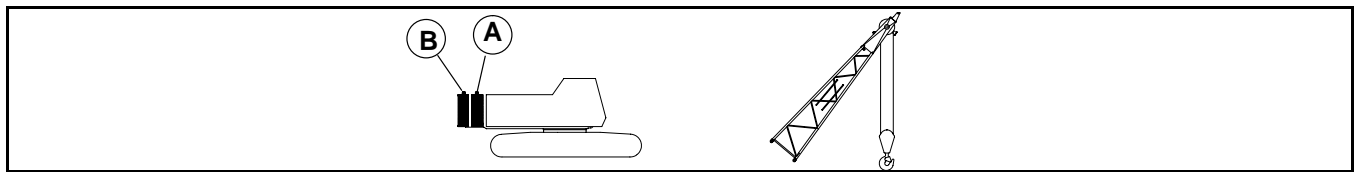

| MAIN BOOM CAPACITIES 160 FT OPEN THROAT TUBE BOOM | | | | | | | |
|---|------------------|------------------|----------------------|-----------|-------------------|-----------------------|-------------|
| Load Radius (Ft.) | Boom Angle (deg) | Over End Blocked | 360° Rotation | | | | |
| | | | Side Frames Extended | | | Side Frames Retracted | |
| | | | AB CTWT (lb) | CTWT (lb) | A CTWT (lb) | 0 CTWT (lb) | A CTWT (lb) |
| 30 | 80.4 | 47,900 | 47,900 | 33,500 | PROHIBITED | | |
| 35 | 78.6 | 44,000 | 40,200 | 26,700 | | | |
| 40 | 76.7 | 39,900 | 33,300 | 21,900 | | | |
| 50 | 73.0 | 29,100 | 24,500 | 15,700 | | | |
| 60 | 69.2 | 22,500 | 18,900 | 11,800 | | | |
| 70 | 65.4 | 18,000 | 15,100 | 9,200 | | | |
| 80 | 61.3 | 14,800 | 12,400 | 7,200 | | | |
| 90 | 57.2 | 12,400 | 10,300 | 5,800 | | | |
| 100 | 52.8 | 10,500 | 8,700 | 4,600 | | | |
| 110 | 48.2 | 9,000 | 7,300 | 3,700 | | | |
| 120 | 43.2 | 7,700 | 6,200 | 2,900 | | | |
| 130 | 37.6 | 6,700 | 5,300 | 2,200 | | | |
| 140 | 31.3 | 5,800 | 4,500 | — | | | |
| 150 | 23.5 | 5,000 | 3,800 | — | | | |
| 160 | 11.6 | 4,300 | 3,200 | — | | | |

| MAIN BOOM CAPACITIES – 190 FT OPEN THROAT TUBE BOOM | | | | | | | |
|---|------------------|------------------|----------------------|-------------------|-------------|-----------------------|-------------|
| Load Radius (Ft.) | Boom Angle (deg) | Over End Blocked | 360° Rotation | | | | |
| | | | Side Frames Extended | | | Side Frames Retracted | |
| | | | AB CTWT (lb) | CTWT (lb) | A CTWT (lb) | 0 CTWT (lb) | A CTWT (lb) |
| 30 | 81.9 | 32,900 | 32,900 | PROHIBITED | | | |
| 35 | 80.4 | 32,500 | 32,500 | | | | |
| 40 | 78.9 | 30,700 | 30,700 | | | | |
| 50 | 75.8 | 25,700 | 24,000 | | | | |
| 60 | 72.6 | 19,600 | 18,400 | | | | |
| 70 | 69.4 | 16,200 | 14,600 | | | | |
| 80 | 66.2 | 13,300 | 11,900 | | | | |
| 90 | 62.8 | 11,000 | 9,800 | | | | |
| 100 | 59.4 | 9,100 | 8,100 | | | | |
| 110 | 55.8 | 7,500 | 6,800 | | | | |
| 120 | 52.1 | 6,100 | 5,700 | | | | |
| 130 | 48.2 | 5,000 | 4,800 | | | | |
| 140 | 44.0 | 4,000 | 4,000 | | | | |
| 150 | 39.4 | 3,100 | 3,100 | | | | |
| 160 | 34.4 | 2,100 | 2,100 | | | | |

| MAIN BOOM CAPACITIES – 170 FT OPEN THROAT TUBE BOOM | | | | | | | |
|---|------------------|------------------|----------------------|-----------|-------------------|-----------------------|-------------|
| Load Radius (Ft.) | Boom Angle (deg) | Over End Blocked | 360° Rotation | | | | |
| | | | Side Frames Extended | | | Side Frames Retracted | |
| | | | AB CTWT (lb) | CTWT (lb) | A CTWT (lb) | 0 CTWT (lb) | A CTWT (lb) |
| 30 | 81.0 | 42,400 | 42,400 | 33,400 | PROHIBITED | | |
| 35 | 79.2 | 40,300 | 40,000 | 26,600 | | | |
| 40 | 77.5 | 37,000 | 33,200 | 21,800 | | | |
| 50 | 74.0 | 28,900 | 24,300 | 15,500 | | | |
| 60 | 70.5 | 22,300 | 18,800 | 11,700 | | | |
| 70 | 66.9 | 17,900 | 15,000 | 9,000 | | | |
| 80 | 63.2 | 14,700 | 12,200 | 7,100 | | | |
| 90 | 59.3 | 12,200 | 10,100 | 5,600 | | | |
| 100 | 55.3 | 10,300 | 8,500 | 4,400 | | | |
| 110 | 51.1 | 8,800 | 7,200 | 3,500 | | | |
| 120 | 46.6 | 7,500 | 6,100 | 2,700 | | | |
| 130 | 41.8 | 6,500 | 5,100 | 2,100 | | | |
| 140 | 36.5 | 5,600 | 4,400 | — | | | |
| 150 | 30.3 | 4,800 | 3,700 | — | | | |
| 160 | 22.8 | 4,100 | 3,100 | — | | | |
| 170 | 11.3 | 3,500 | 2,500 | — | | | |

| MAIN BOOM CAPACITIES – 200 FT OPEN THROAT TUBE BOOM | | | | | | | |
|---|------------------|------------------|----------------------|-------------------|-------------|-----------------------|-------------|
| Load Radius (Ft.) | Boom Angle (deg) | Over End Blocked | 360° Rotation | | | | |
| | | | Side Frames Extended | | | Side Frames Retracted | |
| | | | AB CTWT (lb) | CTWT (lb) | A CTWT (lb) | 0 CTWT (lb) | A CTWT (lb) |
| 35 | 80.9 | 28,600 | 28,600 | PROHIBITED | | | |
| 40 | 79.4 | 27,200 | 27,200 | | | | |
| 50 | 76.5 | 21,500 | 21,500 | | | | |
| 60 | 73.5 | 17,500 | 17,500 | | | | |
| 70 | 70.5 | 14,200 | 14,200 | | | | |
| 80 | 67.4 | 11,700 | 11,700 | | | | |
| 90 | 64.3 | 9,500 | 9,500 | | | | |
| 100 | 61.1 | 7,700 | 7,700 | | | | |
| 110 | 57.8 | 6,200 | 6,200 | | | | |
| 120 | 54.3 | 5,000 | 5,000 | | | | |
| 130 | 50.7 | 3,900 | 3,900 | | | | |
| 140 | 46.9 | 2,800 | 2,800 | | | | |

| MAIN BOOM CAPACITIES – 180 FT OPEN THROAT TUBE BOOM | | | | | | | |
|---|------------------|------------------|----------------------|-------------------|-------------|-----------------------|-------------|
| Load Radius (Ft.) | Boom Angle (deg) | Over End Blocked | 360° Rotation | | | | |
| | | | Side Frames Extended | | | Side Frames Retracted | |
| | | | AB CTWT (lb) | CTWT (lb) | A CTWT (lb) | 0 CTWT (lb) | A CTWT (lb) |
| 30 | 81.5 | 37,500 | 37,500 | PROHIBITED | | | |
| 35 | 79.9 | 36,800 | 36,800 | | | | |
| 40 | 78.2 | 33,900 | 33,000 | | | | |
| 50 | 75.0 | 28,100 | 24,100 | | | | |
| 60 | 71.6 | 21,900 | 18,600 | | | | |
| 70 | 68.2 | 17,700 | 14,800 | | | | |
| 80 | 64.8 | 14,500 | 12,000 | | | | |
| 90 | 61.2 | 12,100 | 10,000 | | | | |
| 100 | 57.5 | 10,200 | 8,300 | | | | |
| 110 | 53.6 | 8,600 | 7,000 | | | | |
| 120 | 49.6 | 7,400 | 5,900 | | | | |
| 130 | 45.3 | 6,100 | 5,000 | | | | |
| 140 | 40.6 | 5,000 | 4,200 | | | | |
| 150 | 35.4 | 4,100 | 3,500 | | | | |
| 160 | 29.5 | 3,300 | 2,900 | | | | |
| 170 | 22.1 | 2,500 | 2,400 | | | | |

This page intentionally left blank

This page intentionally left blank

